

UBR2

UBR2

Dimensions (mm) \varnothing 36 x 21

Voltage (V) 12–230

Speed (rpm) 50 Hz 500
60 Hz 600

Pole number 12

Running torque
(cNm) 50 Hz 0.64
60 Hz 0.61

Power output (W)
50 Hz 0.33
60 Hz 0.38

Gear combination D, M, B, F, V, J



Note: Running torque = Pull-out torque (starting motor at no load, then torque increase)
Running torque and Power output are minimum values, at rated voltage and motor temperature 23°C

Standard Data

Climatic class	wide-spread according to DIN IEC 60721-2-1 : 2015
Ambient temperature operation	°C -15...+55
Ambient temperature storage	°C -20...+100
Thermal resistance at f=0 R _{therm}	27 K/W
Thermal class	105 (A) according to DIN EN 60085 : 2008
Approval	standard (UL/CSA on request)
Mounting	any position
Electrical connection	cable
Protection	IP40 according to DIN EN 60529 : 2014
Weight	60 g
Rotor stalling	motor can be stopped when voltage is applied, without being overheated
Bearings	sintered bronze, self-lubricating
Electric strength	according to DIN EN 60034-1/DIN EN 60335-1

Order Reference

Type	Synchronous Motor		UBR2	0	N	B4	R	E
Rotor shaft, mounting	0	centring 8 mm, shaft 2.0 mm, clip	A	centring 10 mm, shaft 2.0 mm, clip				
	1	centring 8 mm, shaft 1.5 mm, clip	C	centring 10 mm, shaft 1.5 mm, clip				
	3	centring 8 mm, shaft 2.0 mm, screw plate	E	centring 10 mm, shaft 2.0 mm, screw plate				
	4	centring 8 mm, shaft 1.5 mm, screw plate	K	centring 10 mm, shaft 1.5 mm, screw plate				
Approval	N	Approval Standard						
Voltage/Frequency		See next page						
Direction		reversible						
Cable	E	cable 150 mm (other on request)						

All specifications are representative only and maybe subject to variation. For confirmation of values, please contact Johnson Electric.
Please also read "Saia Motors Important Notes" on catalog or at www.johnsonelectric.com/SaiaMotorsNotes

Technical Data

Rated frequency	Hz	50	60			
Speed n	rpm	500	600			
Power consumption	W	1.6	1.6			
Power output	W	0.33	0.38			
Running torque	cNm	0.64	0.61			
Rotor inertia J _R	gcm ²	2.8				
Detent torque M _s	cNm	0.21				
Tolerance of voltage		standard power supply system + 10% / - 10%				
Winding temperature T _{max}	°C	105				
Direction of rotation		reversible				
UBR2 Rated voltage U _N	V	12	24	48	110	230
Duty cycle	%	100	100	100	100	100
Resistance R ₂₀	Ω	87	344	1370	7650	12600
Capacitor C _n (50Hz, 60Hz)	μF/V ±10%	15/20	3.9/40	1/70	0.18/170	0.27;0.22/170
Winding code	50Hz/60Hz	B1/G1	B4/G4	C1/H1	D1/J1	D5/J5
UBR3 Rated voltage U _N	V	12	24	48		
Duty cycle	%	100	100	100		
Resistance R ₂₀	Ω	87	344	1370		
Capacitor C _n (50Hz)	μF/V ±10%	15/20	3.9/40	1/70		
Winding code	50Hz/60Hz	B1/G1	B4/G4	C1/H1		

Circuit diagram Parallel circuit 12V, 24V, 48V, 110V

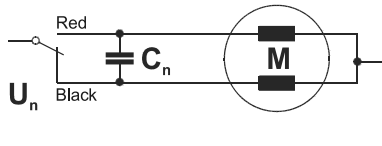

Parallel circuit 230V

R_v=8.2k Ω/1.5W for motors with resistance R₂₀= 7650 Ω, code D1/J1

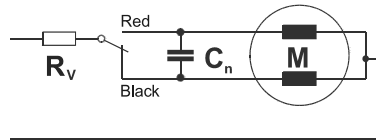

Series circuit 230V (for motors with resistance R₂₀= 12600 Ω)

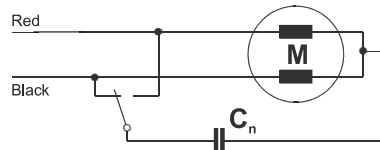

Parallel circuit 230V

C_v=0.22 μF (50Hz)/ 0.18 μF (60Hz)/200 Vac with resistance R₂₀=7650 Ω

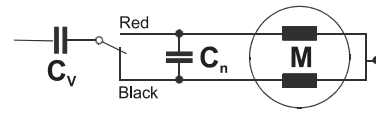

Red = clockwise rotation
Black = counter clockwise rotation

Dimensions Mounting with screw plate

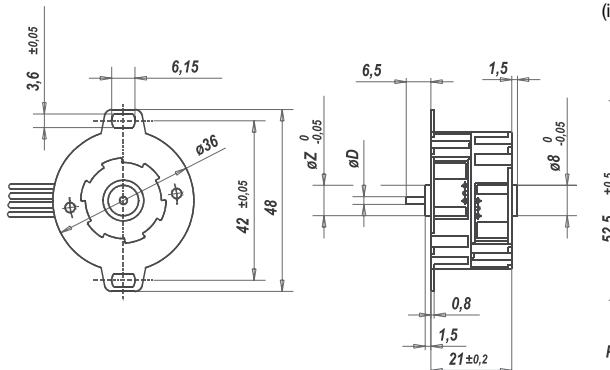

Mounting with snap-on clip
(item no. 4199 48230)

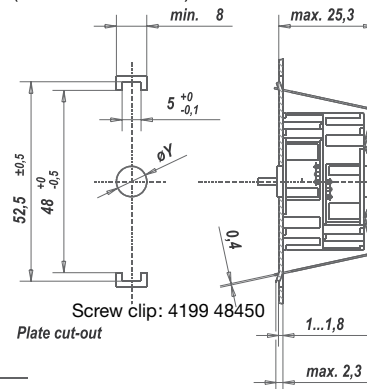

∅D Rotor shaft
∅ 2 h6
∅ 1.5 js8
∅Z ∅Y
8 8F8
10 10F8